



21° ANGLE FRAMING NAILER

Model 98733

SET UP AND OPERATING INSTRUCTIONS



Visit our website at: <http://www.harborfreight.com>



**Read this material before using this product.
Failure to do so can result in serious injury.
SAVE THIS MANUAL.**

Copyright© 2008 by Harbor Freight Tools®. All rights reserved. No portion of this manual or any artwork contained herein may be reproduced in any shape or form without the express written consent of Harbor Freight Tools. Diagrams within this manual may not be drawn proportionally. Due to continuing improvements, actual product may differ slightly from the product described herein. Tools required for assembly and service may not be included.

For technical questions or replacement parts, please call 1-800-444-3353.

Revised 09i

SAVE THIS MANUAL

Keep this manual for the safety warnings and precautions, assembly, operating, inspection, maintenance and cleaning procedures. Write the product's serial number in the back of the manual near the assembly diagram (or month and year of purchase if product has no number). Keep this manual and the receipt in a safe and dry place for future reference.

Safety Alert Symbol and Signal Words

In this manual, on the labeling, and all other information provided with this product:



This is the safety alert symbol. It is used to alert you to potential personal injury hazards. Obey all safety messages that follow this symbol to avoid possible injury or death.

DANGER

DANGER indicates a hazardous situation which, if not avoided, will result in death or serious injury.

WARNING

WARNING indicates a hazardous situation which, if not avoided, could result in death or serious injury.

CAUTION

CAUTION, used with the safety alert symbol, indicates a hazardous situation which, if not avoided, could result in minor or moderate injury.

NOTICE

NOTICE is used to address practices not related to personal injury.

CAUTION

CAUTION, without the safety alert symbol, is used to address practices not related to personal injury.

IMPORTANT SAFETY INSTRUCTIONS

INSTRUCTIONS PERTAINING TO A RISK OF FIRE, ELECTRIC SHOCK, OR INJURY TO PERSONS



WARNING – When using tools, basic precautions should always be followed, including the following:

General

- a. To reduce the risks of electric shock, fire, and injury to persons, read all the instructions before using the tool.

Work area

- a. Keep the work area clean and well lighted. Cluttered benches and dark areas increase the risks of electric shock, fire, and injury to persons.
- b. Do not operate the tool in explosive atmospheres, such as in the presence of flammable liquids, gases, or dust. The tool is able to create sparks resulting in the ignition of the dust or fumes.

- c. **Keep bystanders, children, and visitors away while operating the tool.** Distractions are able to result in the loss of control of the tool.

Personal safety

- a. **Stay alert. Watch what you are doing and use common sense when operating the tool. Do not use the tool while tired or under the influence of drugs, alcohol, or medication.** A moment of inattention while operating the tool increases the risk of injury to persons.

- b. **Dress properly. Do not wear loose clothing or jewelry. Contain long hair. Keep hair, clothing, and gloves away from moving parts.** Loose clothes, jewelry, or long hair increases the risk of injury to persons as a result of being caught in moving parts.

- c. **Avoid unintentional starting. Be sure the switch is off before connecting to the air supply.** Do not carry the tool with your finger on the switch or connect the tool to the air supply with the switch on.

- d. **Remove adjusting keys and wrenches before turning the tool on.** A wrench or a key that is left attached to a rotating part of the tool increases the risk of personal injury.

- e. **Do not overreach. Keep proper footing and balance at all times.** Proper footing and balance enables better control of the tool in unexpected situations.

- f. **Use safety equipment.** A dust mask, non-skid safety shoes and a hard hat must be used for the applicable

conditions. Wear heavy-duty work gloves during use. Wear a full face shield if you are producing metal filings or wood chips.

- g.  **Always wear eye protection.** Wear ANSI-approved safety goggles with side shields during use.

- h.  **Always wear hearing protection when using the tool.** Prolonged exposure to high intensity noise is able to cause hearing loss.

Tool use and care

- a.  **Avoid unintentional misfires. Be sure Trigger (56) is in the OFF position when not in use and before plugging in.** Do

not carry any tool with your finger on the Trigger, whether it is attached to an air source or not. Do not point tool towards yourself or anyone whether it contains nails or not.

- b. **Do not load nails with Trigger or safety depressed.** Unintentional firing may occur. Always assume Nailer contains fasteners.

- c. **Do not load fasteners when Nailer is connected to air hose.** Always assume tool contains fasteners. Unintentional firing may occur.

- d. **Properly adjust Nailer angle to match corresponding fasteners before inserting nail strip.** Failure to do so can cause Nailer to jam and lead to personal and/or property damage.

- e. **Fire nails into an appropriate work surface only.** Do not attempt to fire nails into surfaces too hard to penetrate. Do not drive nails on top of other nails, or at too steep an angle. Nails can ricochet, causing personal injury. Never fire this tool into the air or point it toward yourself or another person.
- f. **Hold tool away from head and body during use.** Tool may kick back, causing injury.
- g. **Do not fire fasteners too close to edge of workpiece.** They may split the workpiece and fly free, causing personal injury.
- h. **Carry tool safely.** Carry tool by handle.
- i. **Use clamps or another practical way to secure and support the workpiece to a stable platform.** Holding the work by hand or against the body is unstable and is able to lead to loss of control.
- j. **Do not force the tool.** Use correct tool for application. The correct tool will do the job better and safer at the rate for which the tool is designed.
- k. **Disconnect the tool from the air source before making any adjustments, changing accessories, or storing the tool.** Such preventive safety measures reduce the risk of starting the tool unintentionally. Turn off and detach the air supply and safely discharge any residual air pressure before leaving the work area.
- l. **Store the tool when it is idle out of reach of children and other un-**

trained persons. A tool is dangerous in the hands of untrained users.

- m. **Maintain the tool with care.** Keep tool clean. A properly maintained tool, reduces the risk of binding and is easier to control.
- n. **Check for misalignment or binding of moving parts, breakage of parts, and any other condition that affects the tool's operation.** If damaged, have the tool serviced before using. Many accidents are caused by poorly maintained tools. There is a risk of bursting if the tool is damaged.
- o. **Use only accessories that are identified by the manufacturer for the specific tool model.** Use of an accessory not intended for use with the specific tool model, increases the risk of injury to persons.

Service

- a. **Tool service must be performed only by qualified repair personnel.**
- b. **When servicing a tool, use only identical replacement parts. Use only authorized parts.**
- c. **Use only the lubricants supplied with the tool or specified by the manufacturer.**

Air source

- a.  **Never connect to an air source that is capable of exceeding 120 PSI.** Over pressurizing the tool may cause bursting, abnormal operation, breakage of the tool or serious injury to persons. Use only clean, dry, regulated compressed air at the rated

pressure or within the rated pressure range as marked on the tool (**70 to 120 PSI**). Always verify prior to using the tool that the air source has been adjusted to the rated air pressure or within the rated air-pressure range.

- b. **Never use oxygen, carbon dioxide, combustible gases or any bottled gas as an air source for the tool.** Such gases are capable of explosion and serious injury to persons.



SAVE THESE INSTRUCTIONS.





SYMBOLS AND SPECIFIC SAFETY INSTRUCTIONS

Symbol Definitions

Symbol	Property or statement
n_o	No-load speed
.../min	Revolutions or reciprocation per minute
PSI	Pounds per square inch of pressure
ft-lb	Foot-pounds of torque
BPM	Blows per minute
CFM	Cubic Feet per Minute flow
SCFM	Cubic Feet per Minute flow at standard conditions
NPT	National pipe thread, tapered
NPS	National pipe thread, straight

Chart continued in next column.

Symbol Definitions

Symbol	Property or statement
	WARNING marking concerning Risk of Eye Injury. Wear ANSI-approved eye protection.
	WARNING marking concerning Risk of Hearing Loss. Wear hearing protection.
	WARNING marking concerning Risk of Respiratory Injury. Wear NIOSH-approved dust mask/respirator.
	WARNING marking concerning Risk of Explosion.

Specific Safety Instructions

- The warnings and precautions discussed in this manual cannot cover all possible conditions and situations that may occur. It must be understood by the operator that common sense and caution are factors which cannot be built into this product, but must be supplied by the operator.
- WARNING:** Some dust created by power sanding, sawing, grinding, drilling, and other construction activities, contains chemicals known [to the State of California] to cause cancer, birth defects or other reproductive harm. Some examples of these chemicals are:
 - Lead from lead-based paints
 - Crystalline silica from bricks and cement or other masonry products
 - Arsenic and chromium from chemically treated lumber
 Your risk from these exposures varies, depending on how often you do this type of work. To reduce your exposure to these chemicals: work in a well ventilated area, and work with approved safety equipment, such as

those dust masks that are specially designed to filter out microscopic particles. (California Health & Safety Code § 25249.5, *et seq.*)

3. Take caution, as some woods contain preservatives such as copper chromium arsenate (CCA) which can be toxic. When nailing these materials, extra care should be taken to avoid inhalation and minimize skin contact.
4. **WARNING:** The brass components of this product contain lead, a chemical known to the State of California to cause birth defects (or other reproductive harm). (California Health & Safety code § 25249.5, *et seq.*)
5. Only use with accessories rated to handle forces exerted by tool during operation. Other accessories not designed for the forces generated may break and forcefully launch pieces.
6. Attach all accessories properly to the tool before connecting the air supply. A loose accessory may detach or break during operation.
7. Obey the manual for the air compressor used to power this tool.
8. Install in-line shutoff valve to allow immediate control over air supply in emergency, even if hose is ruptured.
9. Do not lay tool down until it has completely stopped. Moving parts can grab surface and lead to control loss.

Vibration Precautions

This tool vibrates during use. Repeated or long-term exposure to vibration may cause temporary or permanent physical injury, particularly to the hands,

arms and shoulders. To reduce the risk of vibration-related injury:

1. Anyone using vibrating tools regularly or for an extended period should first be examined by a doctor and then have regular medical check-ups to ensure medical problems are not being caused or worsened from use. Pregnant women or people who have impaired blood circulation to the hand, past hand injuries, nervous system disorders, diabetes, or Raynaud's Disease should not use this tool. If you feel any medical or physical symptoms related to vibration (such as tingling, numbness, and white or blue fingers), seek medical advice as soon as possible.
2. Do not smoke during use. Nicotine reduces the blood supply to the hands and fingers, increasing the risk of vibration-related injury.
3. Wear suitable gloves to reduce the vibration effects on the user.
4. Use tools with the lowest vibration when there is a choice between different processes.
5. Include vibration-free periods each day of work.
6. Grip tool as lightly as possible (while still keeping safe control of it). Let the tool do the work.
7. To reduce vibration, maintain tool as explained in this manual. If abnormal vibration occurs, stop immediately.



**SAVE THESE
INSTRUCTIONS.**

FUNCTIONAL DESCRIPTION

Specifications

Working Air Pressure Range	70-120 PSI* (Depending on nail length and wood density)
Air Inlet	1/4" -18 NPT
Nail Type	.113"-.131" diameter, 2-3/16" to 3-1/2" L, 21° Nails
Fastener Type	Plastic Collated Full Head Nails
Magazine Capacity	60 Nails
Air Consumption	3 CFM @ 90 PSI (Intermittent use) 12 CFM at 90 PSI (Required for continuous use)
Safety Trigger	Single Sequential Actuation

* The pressure setting must not exceed the job site regulations/restrictions.

INITIAL TOOL SET UP/ ASSEMBLY



Read the **ENTIRE IMPORTANT SAFETY INFORMATION** section at the beginning of this manual including all text under subheadings therein before set up or use of this product.

Note: For additional information regarding the parts listed in the following pages, refer to the Assembly Diagram near the end of this manual.

Unpacking

When unpacking, check to make sure item is intact and undamaged. If any parts are missing or broken, call Harbor Freight Tools at the number shown throughout the manual as soon as possible.

- This air tool may be shipped with a protective plug covering the air inlet. Remove this plug before set up.

Air Supply

⚠ WARNING TO PREVENT EXPLOSION:



Use only clean, dry, regulated, compressed air to power this tool. Do not use oxygen, carbon dioxide, combustible gases, or any other bottled gas as a power source for this tool.

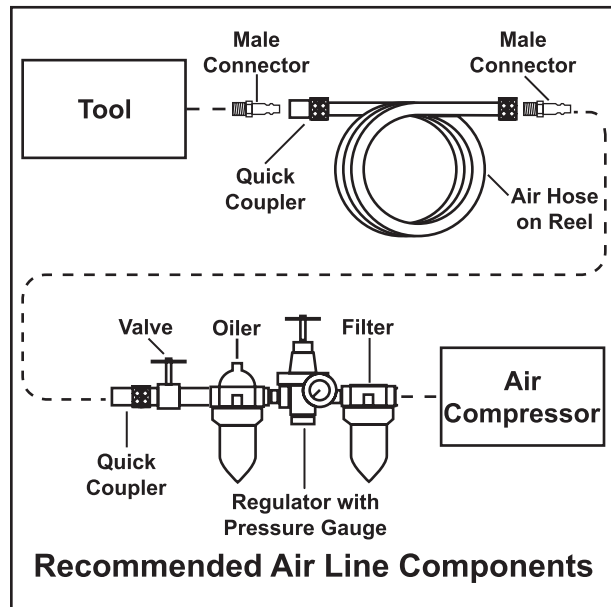

1. Incorporate an in-line oiler, shut-off valve, regulator with pressure gauge, and filter for best service, as shown in the diagram above. **An in-line shut-off valve is an important safety device because it controls the air supply even if the air hose is ruptured.**

Note: If an automatic oiler system is not used, add a few drops of Pneumatic Tool Oil to the airline connection before operation. Add a few more drops after each hour of continual use.

2. Attach an air hose to the compressor's air outlet. Connect the air hose to the air inlet of the tool. Other com-

Revised 09i; 09l

ponents, such as a connector and quick coupler, will make operation more efficient, but are not required.

⚠WARNING! TO PREVENT SERIOUS INJURY FROM ACCIDENTAL OPERATION:

Do not install a female quick coupler on the tool. Such a coupler contains an air valve that will allow the air tool to retain pressure and operate accidentally after the air supply is disconnected.

Note: Air flow, and therefore tool performance, can be hindered by under-sized air supply components.

3. The air hose must be long enough to reach the work area with enough extra length to allow free movement while working.
4. Close the in-line safety valve between the compressor and the tool.
5. Turn on the air compressor according to the manufacturer's directions and allow it to build up pressure until it cycles off.
6. Adjust the air compressor's output regulator so that the air output is enough to properly power the tool, but the output will not exceed the tool's maximum air pressure at any time. Adjust the pressure gradually, while checking the air output gauge to set the right pressure range.
7. Inspect the air connections for leaks. Repair any leaks found.
8. If the tool will not be used at this time, turn off and detach the air supply and safely discharge any residual air pressure.

Note: Residual air pressure should not be present after the tool is disconnected from the air supply. However, it is a good safety measure to attempt to discharge the tool in a safe fashion after disconnecting to ensure that the tool is disconnected and unpowered.

To Attach An Air Connector:

1. Attach a 1/4" Connector (not included) to the Air Plug (83) on the Nailer.
2. Wrap about 3" of pipe thread seal tape (not included) onto threads of the Connector before attaching it to the Air Plug.
3. Connect the 3/8" air source hose to the Nailer.
4. Set the air pressure on compressor to 70 to 120 PSI operating pressure. Do not exceed 120 maximum PSI.
5. Check air connection for leaks. If any are present, ***disconnect the Nailer from air source hose.***

OPERATING INSTRUCTIONS



Read the **ENTIRE IMPORTANT SAFETY INFORMATION** section at the beginning of this manual including all text under subheadings therein before set up or use of this product.

Inspect tool before use, looking for damaged, loose, and missing parts. If any problems are found, do not use tool until repaired.

Testing the Single Sequential Safety Trip Mechanism

WARNING TO PREVENT SERIOUS INJURY

FROM ACCIDENTAL OPERATION: Detach the air supply, safely discharge any residual air pressure in the tool before performing any inspection, maintenance, or cleaning procedures.

TO PREVENT SERIOUS INJURY: Do not adjust or tamper with any control or component in a way not specifically explained within this manual. Improper adjustment can result in tool failure or other serious hazards.

1. **WARNING!** Even though the Nailer should be empty during this procedure, ALWAYS point the Nailer at a piece of scrap wood when testing.
2. Completely empty Magazine (71).

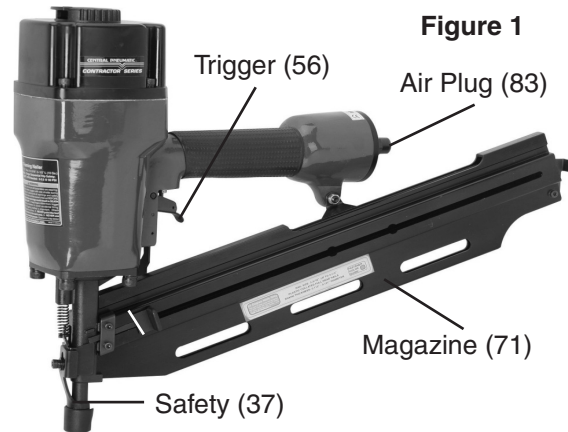

3. The Nailer should not fire if Safety (37) is not depressed against the workpiece.
4. Make sure Trigger (56) and Safety (37) move freely, without sticking.
5. Connect air supply to the Air Plug (83). Set the regulator at the recommended 70 to 120 PSI.
6. Test by depressing Safety (37) against the workpiece without pulling the Trigger. **The Tool must not cycle (fire).** If it cycles (fires), stop immediately and have it repaired by a qualified service technician.
7. Hold tool away or off of workpiece. The Safety should return to its original position. Squeeze Trigger. **The tool should not cycle (fire).** If the tool fires, stop immediately and have it repaired by a qualified service technician.
8. Depress Safety against workpiece and squeeze Trigger. **The tool must cycle (fire) only once.** Release the Trigger and squeeze it again. **The tool must cycle (fire) only once.** With the Trigger held, carefully lift the Nailer and press it against the workpiece again. **The tool must not cycle (fire).** If it fails

to perform in the manner explained in bold, have it repaired by a qualified service technician.

WARNING! Disconnect the Nailer from the air compressor whenever loading or servicing.



ALWAYS WEAR ANSI-APPROVED IMPACT SAFETY GOGGLES WHEN RELOADING OR DOING ANY OTHER MAINTENANCE ON NAILER. Other people in work area must also wear ANSI-approved safety goggles.

Loading Nails

1. **CAUTION!** Make sure Nailer is not attached to the air hose when loading tool.
2. **CAUTION!** Keep Nailer pointed away from yourself and others at all times. Always disconnect Nailer from its air supply before loading nails. Do not load Nails with Trigger (56) or Safety (37) depressed.
3. Pull the Feeder Shoe (69) all the way to the rear, until it latches.
4. Orient a strip of nails with the tips down and drop the strip of nails into Magazine (71).
5. Slide the strip of 60 10-Gauge nails forward in Magazine.
6. Unlatch the Feeder Shoe (69) and allow Feeder Shoe to slide forward against strip of nails.

Operating Framing Nailer

1. Adjust the Exhaust Cover (4) to direct as desired.
2. To fire a nail, place the nose of the Nailer on the workpiece. The Nailer should not fire if the Safety (37) is not depressed. **Once the Safety is depressed, gently and briefly squeeze the Trigger once to fire one nail. Release the Trigger.** Do not fire repeatedly; nails could bounce off on one another, damaging the workpiece or causing personal injury.
3. **Move the Nailer to another spot on the workpiece and squeeze the Trigger again to fire another nail.** Continue firing nails as needed.
4. When the work is completed, disconnect the air supply and remove the nails from the nailer.

OPERATING FRAMING NAILER

1. The depth to which a nail is driven is controlled by the Safety (37).
2. To adjust the depth of drive, loosen the Screw (39). Slide Safety up or down to the desired position. Then, re-tighten the Screw. **Note:** Sliding Safety upward increases the depth of drive. Sliding Safety downward decreases the depth of drive.
3. Test fire a nail, and check its depth of drive. Repeat Step #2 as necessary to achieve the desired depth of drive.

Clearing Jams



WARNING! Anytime *any* maintenance or repairs are done (including clearing jams), wear ANSI-approved impact safety goggles and appropriate hearing protection. **THEN:**

1. **Disconnect the Framing Nailer from its air supply.**
2. **Empty the Magazine (71) completely.**
3. **Try to fire the Nailer into a piece of scrap wood or flooring to ensure that there is no trapped air in the system.**
4. **Always leave Magazine open during maintenance. The Magazine is spring-loaded and may cause parts or a nail to fly out of Nailer.**
5. Always fire the Trigger repeatedly to make sure all of the air is expended from the Nailer.
6. If a nail is jammed in the discharge area, simply remove it with pliers.
7. If a nail is jammed in the magazine, pull the Feeder Shoe (69) all the way back to the disengaged position. Using a screwdriver (not included), attempt to release the jammed nail by probing any of the three openings in the Magazine to release the nail. Pull out the jammed nail and the remainder of the nail strip that is still in the magazine.
8. Dispose of the remaining nail strip; it may be bent or damaged in some other way. Reload the magazine with a new nail strip.
9. Pull back on the Feeder Shoe and with your other hand, pull the tab down on the Lock (75) and guide the Feeder Shoe back into position.
10. **Be careful. When pulling back the Tab, it will spring forward with force.** Keep your fingers clear when releasing.
11. **If you are unable to clear the nail jam using the method prescribed above, the tool should be taken to a qualified service technician for proper servicing.**



WARNING! Anytime *any* maintenance or repairs are done (including clearing jams), wear ANSI-approved impact safety goggles and appropriate hearing protection. **THEN:**

1. **Disconnect the Framing Nailer from its air supply.**
2. **Empty the Magazine (71) completely.**
3. **Try to fire the Nailer into a piece of scrap wood or flooring to ensure that there is no trapped air in the system.**
4. **Always leave Magazine open during maintenance. The Magazine is spring-loaded and may cause parts or a nail to fly out of Nailer.**

USER-MAINTENANCE INSTRUCTIONS



Procedures not specifically explained in this manual must be performed only by a qualified technician.



WARNING TO PREVENT SERIOUS INJURY

FROM ACCIDENTAL OPERATION: Always disconnect Nailer from its compressed air supply and safely discharge any residual air pressure in the tool before performing any inspection, maintenance, or cleaning procedures.

TO PREVENT SERIOUS INJURY FROM TOOL FAILURE: Do not use damaged equipment. If abnormal noise, vibration, or leaking air occurs, have the problem corrected before further use.



TO PREVENT EXPLOSION: Lubricate tool only with specified lubricants. Lubricate the air inlet using only pneumatic tool oil. Lubricate internal mechanism using only white lithium grease. Other lubricants may damage the mechanism and may be highly flammable, causing an explosion.

Cleaning, Maintenance, and Lubrication

Note: Anytime inspection, maintenance and cleaning are done:

1. Disconnect the Framing Nailer from its air supply.
2. Empty Magazine (71) completely.
3. Try to fire the Nailer into a piece of scrap wood or flooring to ensure that it is disconnected and incapable of firing any nails.
4. Always leave Magazine open during maintenance. The Magazine is spring-loaded and may cause parts or a nail to fly out of Nailer
5. BEFORE EACH USE, inspect general condition of Framing Nailer. Check for loose screws, misalignment or binding of moving parts, jammed nails, cracked or broken parts, damaged air supply hose, and any other condition that may affect the safe operation of this tool. If abnormal noise or vibration occurs, immediately disconnect the Nailer from its compressed air supply source and have the problem corrected before further use. Do not use damaged equipment.
6. **PERIODICALLY**, use a premium quality, lightweight oil to lubricate all moving parts.
7. When necessary, wipe with damp cloth.
8. Store in a clean, dry and safe location out of reach of children.
9. **All maintenance, service or repairs not listed in this manual are only to be attempted by a qualified service technician.**

Troubleshooting

Problem	Possible Causes	Likely Solutions
Air leaking in Cylinder Cap (8A).	<ol style="list-style-type: none"> Loose Screw (6). O-ring (9A) is cracked or worn. 	<ol style="list-style-type: none"> Tighten and recheck. Replace O-ring.
Lack of power. Slow to cycle. Low power when shooting and returning.	<ol style="list-style-type: none"> Tool is too dry. Air pressure too low. Exhaust blocked. 	<ol style="list-style-type: none"> Add about 3 drops of pneumatic tool oil into the Air Plug (83). Check to make sure regulator on air compressor is set between 70 PSI and 120 PSI. (70 PSI is the minimum where the Nailer may work. If power is too low, set it between 100-120 PSI.) Clean exhaust channel.
Not shooting fasteners or only intermittent feeding.	<ol style="list-style-type: none"> Damaged Torsion Spring (76). Wrong size of fasteners. Magazine (71) is dirty. 	<ol style="list-style-type: none"> Replace Spring. Use 2-3/16" to 3-1/2", .113"-.131" diameter Nails. Clean Magazine.
Fastener is jammed in tool.	<ol style="list-style-type: none"> Feeder Shoe (69) is broken or worn. Bent fasteners. 	<ol style="list-style-type: none"> Replace Feeder Shoe. Remove bent fasteners. Replace with new Nails.



Follow all safety precautions whenever diagnosing or servicing the tool. Disconnect air supply before service.

PLEASE READ THE FOLLOWING CAREFULLY

THE MANUFACTURER AND/OR DISTRIBUTOR HAS PROVIDED THE PARTS LIST AND ASSEMBLY DIAGRAM IN THIS MANUAL AS A REFERENCE TOOL ONLY. NEITHER THE MANUFACTURER OR DISTRIBUTOR MAKES ANY REPRESENTATION OR WARRANTY OF ANY KIND TO THE BUYER THAT HE OR SHE IS QUALIFIED TO MAKE ANY REPAIRS TO THE PRODUCT, OR THAT HE OR SHE IS QUALIFIED TO REPLACE ANY PARTS OF THE PRODUCT. IN FACT, THE MANUFACTURER AND/OR DISTRIBUTOR EXPRESSLY STATES THAT ALL REPAIRS AND PARTS REPLACEMENTS SHOULD BE UNDERTAKEN BY CERTIFIED AND LICENSED TECHNICIANS, AND NOT BY THE BUYER. THE BUYER ASSUMES ALL RISK AND LIABILITY ARISING OUT OF HIS OR HER REPAIRS TO THE ORIGINAL PRODUCT OR REPLACEMENT PARTS THERETO, OR ARISING OUT OF HIS OR HER INSTALLATION OF REPLACEMENT PARTS THERETO.

PARTS LIST

Part	Description
1	Screw
2	Spring Washer
3	Bushing
4	Exhaust Cover
5	Seal
6	Screw
7	Spring Washer
8A	Cylinder Cap
9A	O-ring sealing
10	Washer
11	Valve Seat
12	Spring
13	O-Ring (M57.5 x 3.6)
14	O-Ring (M72.4 x 3.5)
15	Valve
16	Screw
17	Cylinder Seal
18	Collar
19	O-Ring (M54.4 x 4)
20	Piston
21	Cylinder
22	O-Ring (M67 x 3)
23	O-Ring (M60.25 x 2.5)
24	Restrictive Seal
25	O-Ring (M97.5 x 3.5)
26	Bumper A
27	Bumper B
28	Body

Part	Description
29	O-Ring (M62.3 x1.8)
30	Nose
31	Spring Washer
32	Screw
33	Spring
34	Safety Bracket
35	Screw
36	Bushing
37	Safety
38	Washer
39	Screw
40	Rubber Cover
41	Spring Pin
42	Safety Guide
43	O-Ring (M18.4 x 2.4)
44	O-Ring (M20.3 x 1.5)
45	Valve Set
46	O-Ring (M9.5 x 1.9)
47	O-Ring (M10.3 x 1.9)
48A	Trigger Valve Head
49	O-Ring (M12.8 x 1.9)
50	Spring
51	O-Ring (M5.5 x 1.5)
52	Trigger Valve Stem
53	O-Ring (M24.8 x 2)
54	Trigger Valve Guide
55	Trigger Spring
56	Trigger

Part	Description
57	Seal
58	Pin
59	Rail
60	Washer
61	Nut
62	Washer
63	Coil Spring
64	Pin
65	Bushing
66	Screw
67	Block
68	Washer
69	Feeder Shoe
70	Screw
71	Magazine
72	Screw
73	Support
74	Nut
75	Lock
76	Torsion Spring
77	Bushing
78	Nut
79	Nut
80	Soft Grip Sleeve
81	O-Ring (65.4x2.5)
82	End Cap
83	Air Plug

ASSEMBLY DIAGRAM

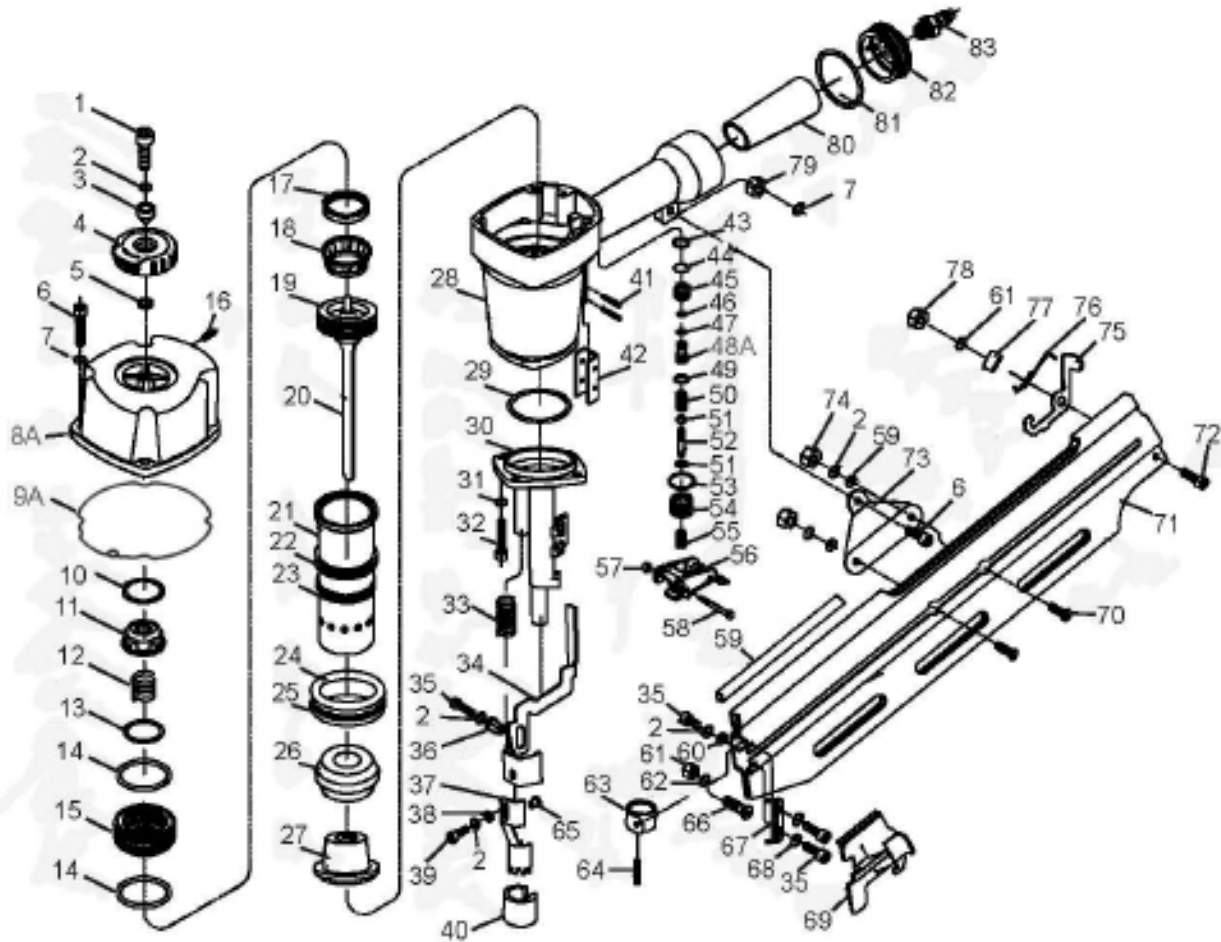

Record Product's Serial Number Here: _____

Note: If product has no serial number, record month and year of purchase instead.

Note: Some parts are listed and shown for illustration purposes only, and are not available individually as replacement parts.

LIMITED 1 YEAR WARRANTY

Harbor Freight Tools Co. makes every effort to assure that its products meet high quality and durability standards, and warrants to the original purchaser that this product is free from defects in materials and workmanship for the period of one year from the date of purchase (90 days if used by a professional contractor or if used as rental equipment). This warranty does not apply to damage due directly or indirectly, to misuse, abuse, negligence or accidents, repairs or alterations outside our facilities, normal wear and tear, or to lack of maintenance. We shall in no event be liable for death, injuries to persons or property, or for incidental, contingent, special or consequential damages arising from the use of our product. Some states do not allow the exclusion or limitation of incidental or consequential damages, so the above limitation of exclusion may not apply to you. THIS WARRANTY IS EXPRESSLY IN LIEU OF ALL OTHER WARRANTIES, EXPRESS OR IMPLIED, INCLUDING THE WARRANTIES OF MERCHANTABILITY AND FITNESS.

To take advantage of this warranty, the product or part must be returned to us with transportation charges prepaid. Proof of purchase date and an explanation of the complaint must accompany the merchandise. If our inspection verifies the defect, we will either repair or replace the product at our election or we may elect to refund the purchase price if we cannot readily and quickly provide you with a replacement. We will return repaired products at our expense, but if we determine there is no defect, or that the defect resulted from causes not within the scope of our warranty, then you must bear the cost of returning the product.

This warranty gives you specific legal rights and you may also have other rights which vary from state to state.

3491 Mission Oaks Blvd. • PO Box 6009 • Camarillo, CA 93011 • (800) 444-3353